

CNC APEX 3R

Reliable turnkey solutions for any application requiring value, performance and versatility.

fotomoriz

Soluciones inteligentes de impresión

www.fotomoriz.com

mercadeo@fotomoriz.com

PBX (57-1) 327 6868

Bogotá - Colombia



MULTICAM
Complete CNC Solutions

INTRODUCING THE NEXT GENERATION OF CNC ROUTERS

APEX3R

The Apex3R CNC Router is a next generation machine loaded with standard features normally associated with more expensive systems. The all-steel tube frame and moving gantry design allows for machining of large parts while maintaining a small, space-saving footprint.

Designed for a wide range of applications, the Apex3R is the perfect solution for companies looking for both value and high performance in a CNC Router.



FEATURES & SPECIFICATION GUIDE **PERFORMANCE / EASE OF USE / PRODUCTIVITY**

PERFORMANCE

No machine offers more features than the innovative and versatile Apex3r CNC Router

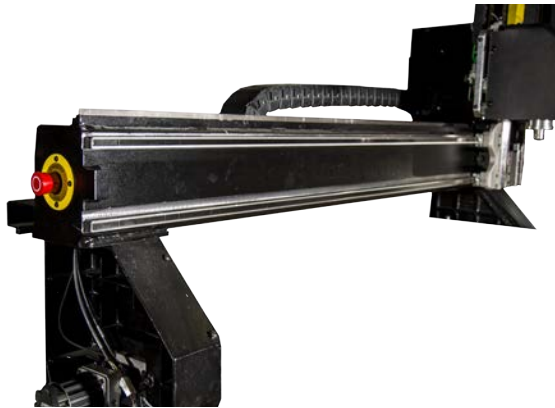

Gantry

Custom Engineered for Maximum Rigidity

Made of 3/8" thick steel tube, the gantry is welded, stress relieved and precision machined.

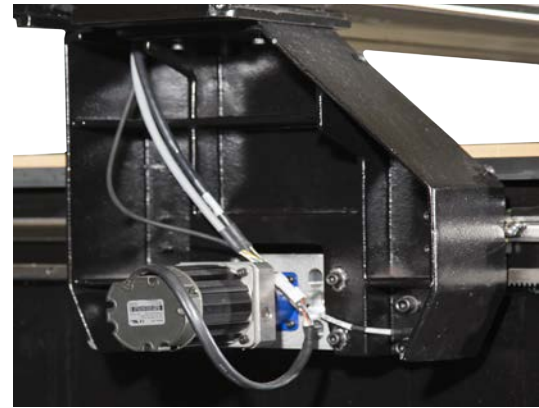

Gantry Supports

High Strength, Minimal Vibration

In conjunction with wide X-axis bearing spacing, cast-iron gantry supports help dampen vibration and give the structural tube gantry extremely rigid support.

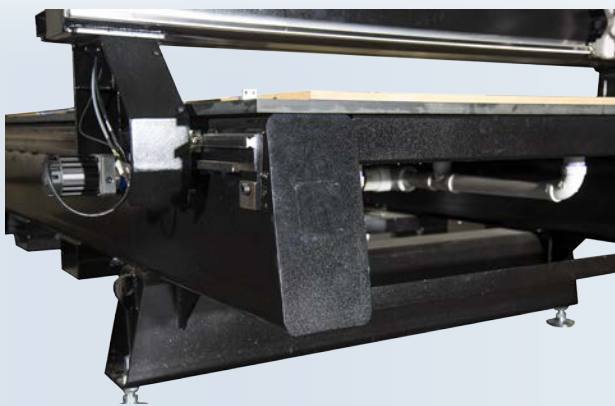

Base Frame

Solid, Heavy-Duty Construction

The Apex's base is a rigid 3/8" thick tube frame that is welded, stress relieved and precision machined. It provides a heavy and accurate platform that translates into gentle motion for clean, smooth cuts.



Linear Bearings

Smooth Motion, Minimal Friction

The linear bearing profile rails are designed to increase the longevity of your machine by constantly applying lubrication on all points of contact along the rail..



Working Surfaces

Versatile, Effective, Multi-functional

The standard working surface is 1" thick 80-82 Durometer phenolic with a machined 30mm grid pattern utilizing 25" x .25" foam gasket tape. Phenolic makes an excellent work surface because of its dependable mechanical strength and dimensional stability.



EZ Control

Powerful, Intuitive Control

MultiCam EZ Control provides all users, from novice to advanced, with the most powerful and easy-to-use control system available on the market today.

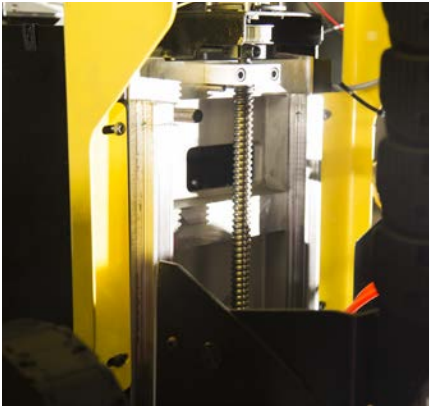

Z-Screw Assembly

The Apex3R ball screw assembly has 12" of Z stroke to handle a wide variety of tooling. Precision dual angular contact ball bearings support the 12-mm ball screw within a steel housing.



Linear ATC **Automatic Tool Changer**

The Apex3R offers a low cost alternative to automatic tool changing. It features a linear tool rack holder mounted at the end of the material process area.



Digital Servo Drives **Accurate & Reliable**

Digital servo drives and brushless digital AC servo motors for a digital vector servo drive system that is standard on all Apex3R machines.

SPECIFICATIONS

MultiCam's Apex3R Router makes it easy for you to get the most out of your machine.

Standard Features:

- MultiCam EZ Control® handheld operator interface
- EZ Suite® Software
- Heavy, all-steel tube frame construction
- High-speed 3-axis motion control system
- Unlimited file size transfer capabilities
- Standard Ethernet, Static or DHCP capable
- Brushless 3 phase servo motors coupled with digital AC servo drives
- Tool and Material Calibration
- 10:1 Precision Planetary Gearboxes

Options:

- Linear automatic tool changer
- Automatic Material Surfacing Probe
- Automatic Tool Length Calibration Probe
- MultiCam CNC Dual Knife with optional cutting heads
- MultiVision™ Digital Registration System
- Coolant mist systems for non-ferrous metal cutting
- Vision systems for print registration compensation
- Tangential knife cutters
- Laser Pointer
- Pop-Up Pins
- Active Dust Boot
- Automatic Tool Calibrations

Specifications:

- Z-Axis Clearance: 6"; optional 8"
- Z-Axis Travel: 12"
- Slew (Diagonal): 2600 IPM
- Slew Acceleration: 42 in/sec²
- Feed (Linear): 12-1600 IPM
- Feed Acceleration: 30 in/sec²
- Drive System X&Y: Helical Rack and Pinion
- Drive System Z: 12mm Ball Screw
- Work Surface: 1" Phenolic

SPECIFICATIONS

WITHOUT KNIFE

MODEL	L	L1	W	W1	H	WORKING AREA (IN.)	WORKING AREA (MM)	WEIGHT (LBS.)
3-103-R	168	133.5	68	84.5	75	50"x100"	1356x2540	3150
3-204-R	186	154.5	94.5	78	75	60"x120"	1596x3073	3750
3-304-R	186	154.5	114.5	98	75	84"x120"	2106x3073	4350

WITH KNIFE

MODEL	L	L1	W	W1	H	WORKING AREA (IN.)	WORKING AREA (MM)	WEIGHT (LBS.)
3-103-R	168	133.5	94	84.5	75	50"x100"	1356x2540	3150
3-204-R	186	154.5	99	78	75	60"x120"	1596x3073	3750
3-304-R	186	154.5	123	98	75	84"x120"	2106x3073	4400

ALL NUMBERS HAVE BEEN ROUNDED. "W" FOR KNIFE MACHINES IS END OF GANTRY TO END OF RISER COVER (MAXIMUM WIDTH OF MACHINE).

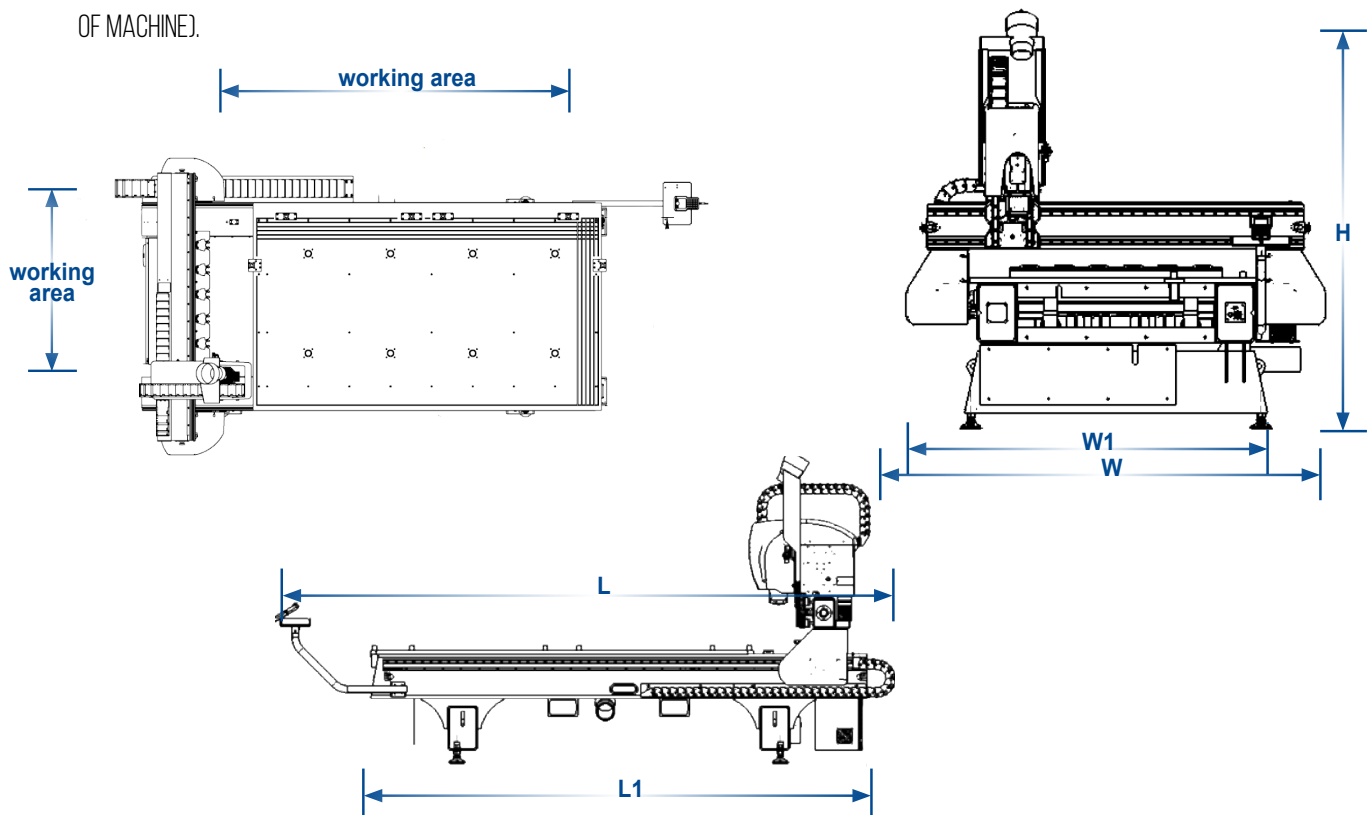



MULTICAM
Complete CNC Solutions

1025 West Royal Lane
DFW Airport, TX 75261

fotomoriz

Soluciones inteligentes de impresión

www.fotomoriz.com

mercadeo@fotomoriz.com

PBX (57-1) 327 6868

Bogotá - Colombia



By phone:
+1 972.929.4070
Hotline:
855.894.3136



By email:
sales@multicam.com



Or online at:
www.multicam.com