

CNC

APEX^{1R}

Reliable turnkey solutions for applications requiring value, performance, accuracy, and versatility.



fotomoriz

Soluciones inteligentes de impresión

www.fotomoriz.com

mercadeo@fotomoriz.com

PBX (57-1) 327 6868

Bogotá - Colombia



MULTICAM
Complete CNC Solutions

MAXIMUM FLEXIBILITY, MADE AFFORDABLE

APEX1R

MultiCam heard the industry challenge and has built the first fully capable, turn-key CNC solution at an affordable price! This rigid and reliable servo driven machine has four spindle options and either a single or dual tangential knife option. Both the spindle and knife are perfectly suited to cut a multitude of materials with unsurpassed performance and cut quality.



FEATURES & SPECIFICATION GUIDE

PERFORMANCE / EASE OF USE / PRODUCTIVITY

PERFORMANCE

No machine in its class offers more standard features than the innovative and versatile AEPX1R CNC Router.

000 Series



Gantry

Custom Engineered for Maximum Rigidity

MultiCam engineered the gantry tube from aircraft-quality aluminum extrusion for maximum stiffness allowing users to cut at higher speeds for optimum edge quality.



Working Surfaces

Versatile, Effective, Multi-functional

The standard working surface is 1" thick 80-82 Durometer phenolic with a machined 30mm grid pattern and vacuum ports. Phenolic makes an excellent work surface because of its dependable mechanical strength and dimensional stability.



Base Frame

Solid, Heavy-Duty Construction

A solid-steel frame design is standard on the APEX1R. It provides a heavy and accurate platform that translates into gentle motion for clean, smooth cuts.



Helical Rack

Smooth Motion, Minimal Friction

Helical racks are standard on the APEX1R and provide smooth and accurate motion as the gantry moves through all axes.

PERFORMANCE

No machine offers more features than the innovative and versatile APEX1R CNC Router.



Z-Screw Assembly **Designed to Last**

The APEX1R utilizes a 5/8" diameter carbon steel ball screw. For high axial force loads, a precision mounting block with dual angular contact ball bearings holds it firmly in place.



Servo Drive System **Smooth & Accurate**

The APEX1R, comes standard with a Robust Drive Motor system with Servo Drives to allow for powerful yet fluid motion.



Router Spindle **High RPM's for Increased Capabilities**

The APEX1R comes equipped with a high-frequency spindle for optimal durability when cutting thin or dense materials.



Coreo Software **Workflow Management**

The APEX1R comes with the intuitive Coreo CAD/CAM software. Divided into five segments, Coreo is designed to efficiently streamline work processes and maximize efficiency.

EASE OF USE

MultiCam's APEX1R makes it easy for you to get the most out of your machine.



EZ Control Powerful, Intuitive Control

MultiCam's EZ Control provides all users, from novice to advanced, with the most powerful and easy-to-use control system available on today's market. New operators can be productive in as little as an hour!



MultiVision Dynamic Digital Registration

MultiVision provides additional flexibility by visually recognizing media registration marks and automatically compensating for skew and image drift.

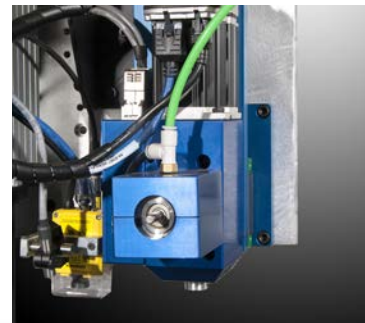

Tangential Knife Enhanced Cutting Capabilities

The programmable tangential knife expands the capabilities of the APEX1R by allowing a wide range of materials to be cut with an oscillating or non-oscillating knife option.



PRODUCTIVITY

OPTIONS:



Auto-Mister Minimize Tool Wear

The auto-mister is designed for the use of cutting non-ferrous metals. The micro-mist system helps lubricate the tool when cutting, maximizing edge quality and minimizing tool wear.



Laser Pointer Decrease Job Set-Up Times

Quickly and accurately identify reference points on the material to minimize job set-up time.

Features:

- Solid Steel Frame Construction
- High-Frequency Spindles
- Cast Dust Collector Shroud/Pressure Foot
- High-Speed Motion Controller
- Precision Dual X-Axis Drives
- EZ Control User-Friendly Handheld Operator Interface
- 20mm Linear Bearing Rails
- 10:1 Precision Planetary Gearboxes
- Tangential Knife (Dual or Single) (Option)
- MultiVision Digital Registration System (Option)
- Four Zone Vacuum Work Surface

Model	Length	Width	Height	Working Area	Weight
103	151in/3835mm	81in/2057mm	78in/1981mm	48inX96in 1219mmX2438mm	1700lbs 771kgs
204	177.5in/4508mm	93in/2362mm	78in/1981mm	60inX120in 1524mmX3048mm	2200lbs 997kgs
304	177.5in/4508mm	80in/2032mm	78in/1981mm	83inX121in 2108mmX3073mm	2600lbs 1179kgs

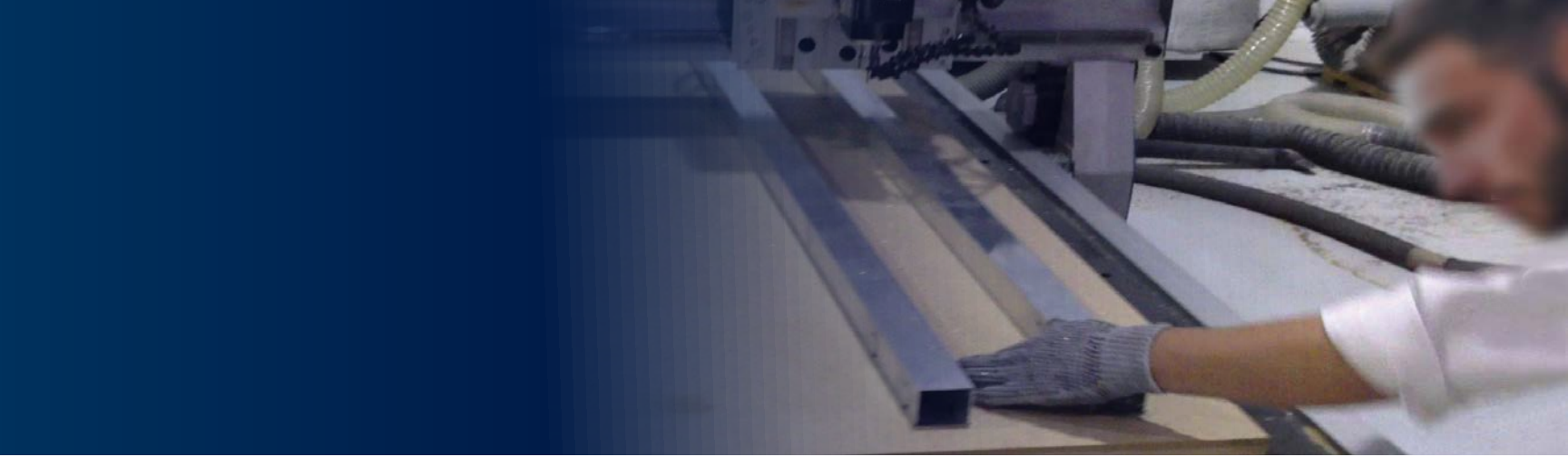

SPECIFICATIONS

Z-Axis Clearance	5"
Z-Axis Travel:	7"
Slew (Diagonal)	1,900 IPM
Slew Acceleration	30 in/sec ²
Feed (Linear)	1,350 IPM
Feed Acceleration	20 in/sec ²
Drive System (X&Y Axes)	Helical Rack & Pinion
Drive System (Z Axis)	Ball Screw
Standard Work Surface	1" Phenolic 4 Zone

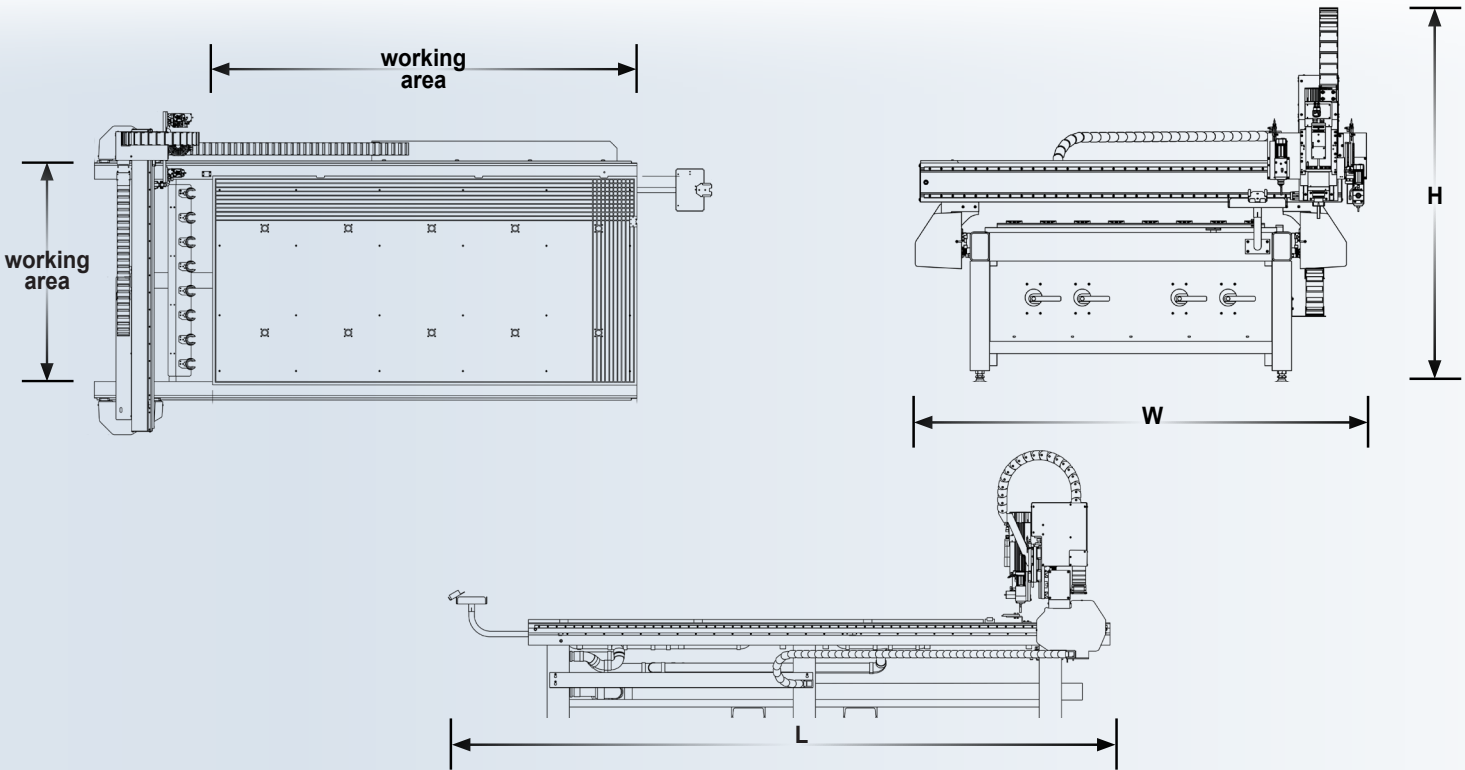



MULTICAM
Complete CNC Solutions

1025 West Royal Lane
DFW Airport, TX 75261

fotomoriz

Soluciones inteligentes de impresión

www.fotomoriz.com

mercadeo@fotomoriz.com

PBX (57-1) 327 6868

Bogotá - Colombia



By phone:
+1 972.929.4070
Hotline:
855.894.3136



By email:
sales@multicam.com



Or online at:
www.multicam.com